

THERMA V™ R32 R32 HYDROPLIT HYDRO BOX

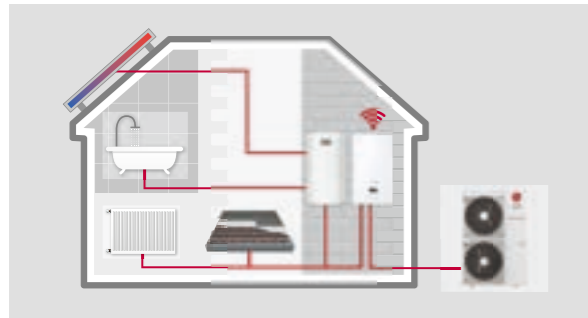

Energy Label

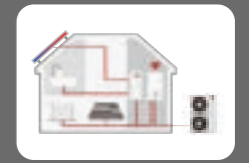
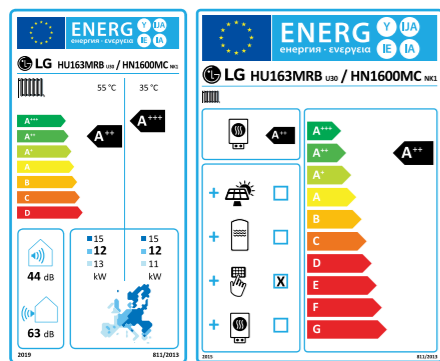

* 16kW 30 model.
* A+++ to D scale.

Excellent Performance & Efficiency



User Convenience

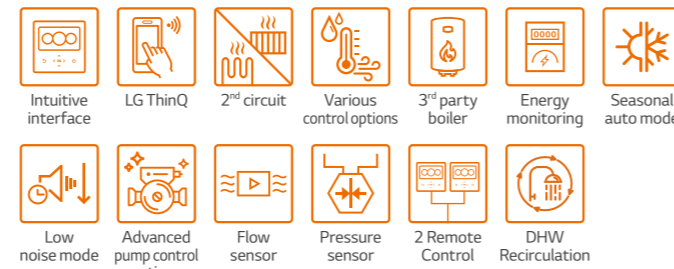

Easy Installation & Maintenance

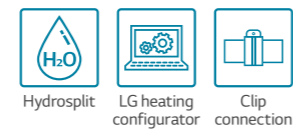

* Detailed description for each function is presented on page 28 - 35.

R32 Hydrosplit Hydro Box Introduction

The LG THERMA V Hydrosplit series separates the Indoor unit (IDU) and outdoor unit (ODU), connecting them via water pipes. The unit's heat exchanger is located within the ODU, reducing the risk of indoor refrigerant leakage. THERMA V R32 Hydrosplit Hydro Box is a solution providing space heating and cooling with high installation flexibility thanks to the characteristic of being a wall mounted type.

Key Components

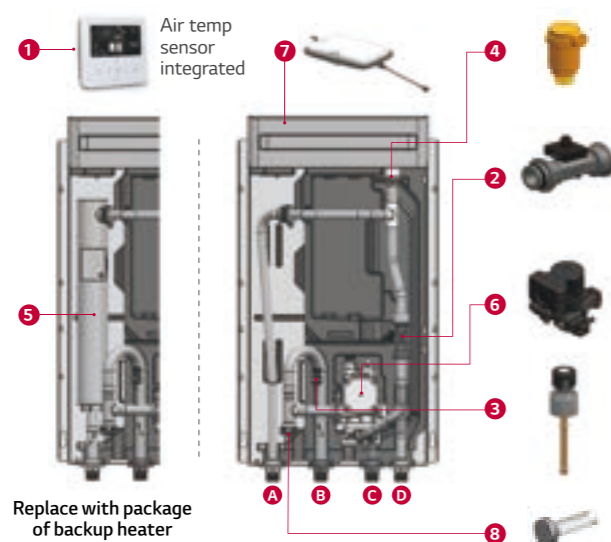

- 1 Standard III Remote Controller (attached on the front panel)
 - 2 Flow sensor (SIKA)
 - 3 Water pressure sensor (SENSATA)
 - 4 Air vent valve
 - 5 Backup electric heater (6kW, accessory)
 - 6 Water pump (GRUNDFOS)
 - 7 Expansion vessel (8L)
 - 8 Strainer
- A Heating circuit outlet pipe (male PT 1")
 B Heating circuit inlet pipe (male PT 1")
 C Outlet pipe to outdoor unit (male PT 1")
 D Inlet pipe from outdoor unit (male PT 1")

Replace with package of backup heater

Hydrosplit Concept

The THERMA V R32 Hydrosplit Hydro Box connects an IDU and ODU by water pipes due to the heat exchanger's location in the outdoor unit, thus reducing the risk of indoor refrigerant leakage.



No Risk of Indoor Refrigerant Leakage

As there is no refrigerant inside of room, no need to consider minimum floor area requirement for IDU due to R32 refrigerant. As a result, it is possible to expand living area more for other purpose.

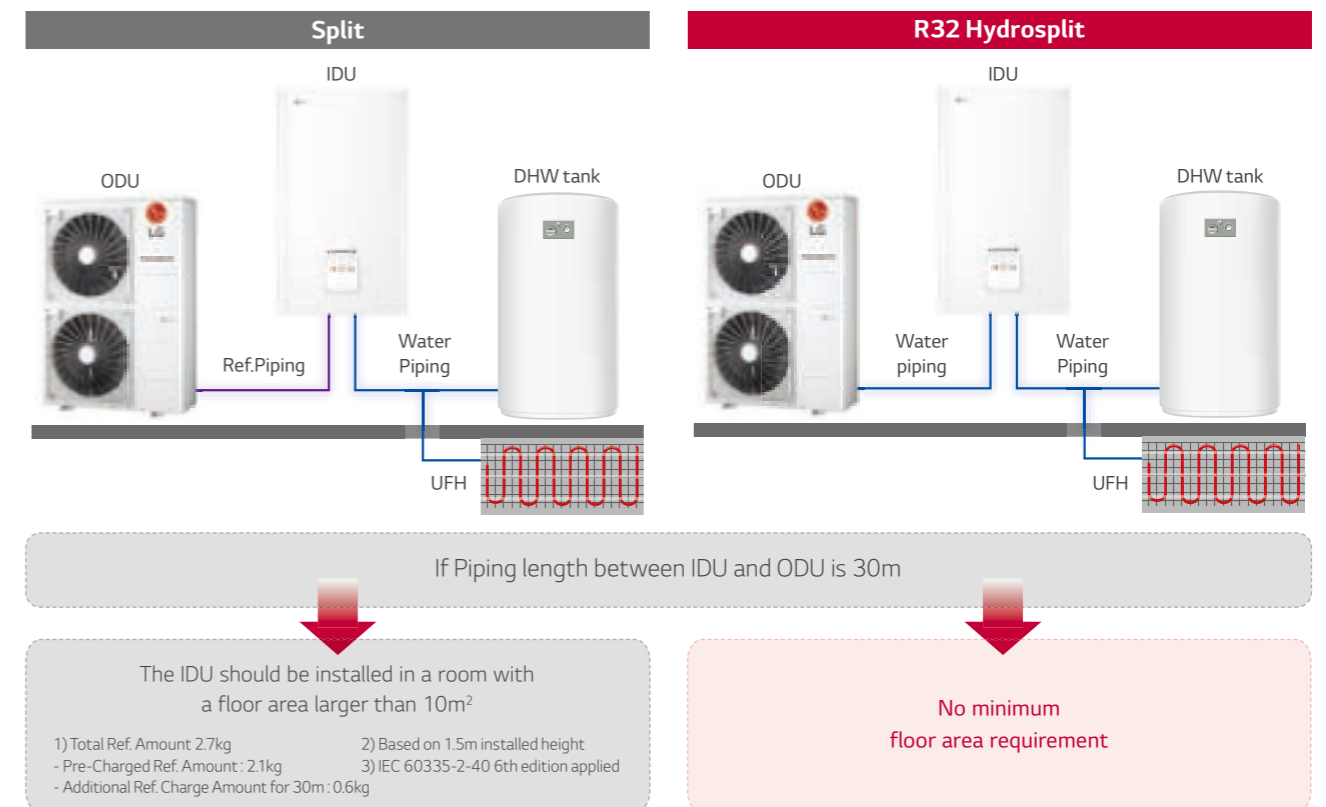

THERMA V™ R32 HYDROSPLIT HYDRO BOX

PRODUCT SPECIFICATION

R32 Hydrosplit Hydro Box



Indoor Unit

HN1600MC NK1

Outdoor Unit

HU121MRB U30 / HU123MRB U30

HU141MRB U30 / HU143MRB U30

HU161MRB U30 / HU163MRB U30



Features

- Water pipes connects IDU & ODU
- SCOP up to 4.60 (Average climate / Low temp. application) : A+++
SCOP up to 3.50 (Average climate / Mid temp. application) : A++
- COP up to 5.04 (Outdoor air 7°C / Leaving water 35°C)
- 100% heating capacity at -7°C OAT (@ LWT 35°C)
- Wide operation range (ambient : -25 ~ 35°C / water side : 15 ~ 65°C)
- Built-in water flow & pressure sensors to monitor real-time water circuit
- R32 refrigerant with reduced global warming potential (GWP)
- R1 compressor
- Black Fin heat exchanger
- LG ThinQ
- KEYMARK / EHPA (for Germany, Austria) / MCS / EUROVENT certification

* Only the outdoor units are registered in EHPA certification.

Model Line-up

Category	Unit	Model Name		
		Capacity (kW)		
		12.0	14.0	16.0
1 Phase Model 220 ~ 240V, 1Ø, 50Hz	Outdoor Unit	HU121MRB U30	HU141MRB U30	HU161MRB U30
	Indoor Unit	HN1600MC NK1		
3 Phase Model 380 ~ 415V, 3Ø, 50Hz	Outdoor Unit	HU123MRB U30	HU143MRB U30	HU163MRB U30
	Indoor Unit	HN1600MC NK1		

Seasonal Energy

Description	Outdoor Unit	Indoor Unit	HU121MRB U30 (1Ø)	HU141MRB U30 (1Ø)	HU161MRB U30 (1Ø)	
			HU123MRB U30 (3Ø)	HU143MRB U30 (3Ø)	HU163MRB U30 (3Ø)	
Space Heating (according to EN14825)	Average Climate Water Outlet 35°C	-	HN1600MC NK1			
			SCOP	4.60	4.57	4.55
			Seasonal Space Heating Efficiency (η _s)	181	180	179
	Average Climate Water Outlet 55°C	-	Seasonal Space Heating Eff. Class (A+++ to D scale)	A+++	A+++	A+++
			SCOP	3.50	3.47	3.45
			Seasonal Space Heating Efficiency (η _s)	137	136	135
			Seasonal Space Heating Eff. Class (A+++ to D scale)	A++	A++	A++

Nominal Capacity and Nominal Power Input

Description	OAT (DB)	LWT (DB)	Outdoor Unit	HU121MRB U30 (1Ø)	HU141MRB U30 (1Ø)	HU161MRB U30 (1Ø)	
				HU123MRB U30 (3Ø)	HU143MRB U30 (3Ø)	HU163MRB U30 (3Ø)	
Nominal Capacity	Heating	7°C	kW	HN1600MC NK1			
		7°C		12.00	14.00	16.00	
		2°C		11.00	11.50	12.00	
	Cooling	35°C		11.00	12.00	13.80	
		18°C		12.00	14.00	16.00	
		7°C		12.00	14.00	16.00	
Nominal Power Input	Heating	7°C	kW	2.38	2.86	3.33	
		7°C		3.79	4.04	4.29	
		2°C		3.01	3.31	3.83	
	Cooling	35°C		2.53	3.26	4.00	
		18°C		4.44	5.38	6.40	
		7°C		4.44	5.38	6.40	
COP	Heating	7°C	W/W	5.04	4.89	4.80	
		7°C		2.90	2.85	2.80	
		2°C		3.65	3.63	3.60	
EER	Cooling	35°C		W/W	4.75	4.30	4.00
		7°C			2.70	2.60	2.50

PRODUCT SPECIFICATION

R32 Hydrosplit Hydro Box

Product Specification (Outdoor Unit)

Technical Specification			Unit	HU121MRB U30	HU141MRB U30	HU161MRB U30	HU123MRB U30	HU143MRB U30	HU163MRB U30
Operation Range (outdoor temp.)	Heating	Min. - Max.	°C DB	-25 - 35					
	Cooling								
Compressor	Quantity	EA	1						
	Type	-	Hermetic Sealed Scroll						
Refrigerant	Type	-	R32						
	GWP (global warming potential)	-	675						
	Precharged Amount	g	2,100						
	t-CO ₂ eq	-	1,418						
Piping Connections	Water Circuit	Inlet	mm (inch)	Male PT 1" according to ISO 7-1 (tapered pipe threads)					
		Outlet	mm (inch)	Male PT 1" according to ISO 7-1 (tapered pipe threads)					
Rated Water Flow Rate (at LWT 35°C)			LPM	34.5	40.3	46.0	34.5	40.3	46.0
Sound Power Level	Heating	Rated	dB(A)	61	62	63	61	62	63
Sound Pressure Level (at 1m)	Heating	Rated	dB(A)	53	54	55	53	54	55
Dimensions	Unit	W x H x D	mm	950 x 1,380 x 330					
Weight	Unit		kg	91.7					
Exterior	Color / RAL Code		-	Warm Gray / RAL 7044					
	Voltage, Phase, Frequency		V, Ø, Hz	220-240, 1, 50			380-415, 3, 50		
Power Supply	Rated Running Current	Heating	A	10.6	12.7	14.8	3.5	4.2	4.9
		Cooling	A	11.2	14.4	17.7	3.7	4.8	5.9
	Recommended Circuit Breaker		A	40			16		
Wiring Connections	Power Supply Cable (included earth, H07RN-F)		mm ² x cores	6.0 x 3C			2.5 x 5C		

Note

- Due to our policy of innovation some specifications may be changed without notification.
- Wiring cable size must comply with the applicable local and national codes. Especially the power cable and circuit breaker should be selected in accordance with that.
- Sound power level is measured on the rated condition in according with ISO 9614 standard. Sound pressure level is converted from sound power level based on tonality penalty of 0dB and installation in free-field. Therefore, these values can be increased owing to ambient conditions during operation. Rated sound power level is according to the EN12102-1 under conditions of the EN14825.
- Performances are based on the following conditions (It is according to EN14511):
 - Interconnected Pipe Length is standard length and difference of Elevation
- This product contains Fluorinated greenhouse gases. (Outdoor - Indoor Unit) is 0m.

Product Specification (Indoor Unit)

Technical Specification			Unit	HN1600MC NK1
Operation Range (leaving water)	Heating	Min. - Max.	°C DB	15 - 65
	Cooling			5 - 27 (16 - 27) ¹⁾
Flow Sensor	DHW			15 - 80 ²⁾
Flow Sensor	Measuring Range	Min. - Max.	l/min	5 - 80
Water Pressure Sensor	Measuring Range	Min. - Max.	bar(G)	0 - 20
Expansion Vessel	Volume		l	8
Safety Valve	Pressure Limit	Upper limit	bar	3
Piping Connections	Water Circuit	Outlet to Heat Load	Inch	Male PT 1" according to ISO 7-1 (tapered pipe threads)
		Inlet from Heat Load		Male PT 1" according to ISO 7-1 (tapered pipe threads)
		Outlet to Outdoor Unit		Male PT 1" according to ISO 7-1 (tapered pipe threads)
		Inlet from Outdoor Unit		Male PT 1" according to ISO 7-1 (tapered pipe threads)
Wiring Connections	Power and Communication Cable (included earth, H07RN-F)		mm ² x cores	0.75 x 4C
Sound Power Level	Heating	Rated	dB(A)	44
Dimensions	Unit	W x H x D	mm	490 x 850 x 315
Weight	Unit		kg	30.5
Exterior	Color / RAL Code		-	Noble White / RAL 9016

- When fan coil unit not used.
- DHW 58-80°C Operating is available only when the booster heater is operating.

Note

- Due to our policy of innovation some specifications may be changed without notification.
- Wiring cable size must comply with the applicable local and national codes. Especially the power cable and circuit breaker should be selected in accordance with that.
- Sound power level is measured on the rated condition in according with ISO 9614 standard. Sound pressure level is converted from sound power level based on tonality penalty of 0dB and installation in free-field. Therefore, these values can be increased owing to ambient conditions during operation. Rated sound power level is according to the EN12102-1 under conditions of the EN14825.
- This product contains Fluorinated greenhouse gases.

Accessory Parts (Optional Accessory)

Backup Heater

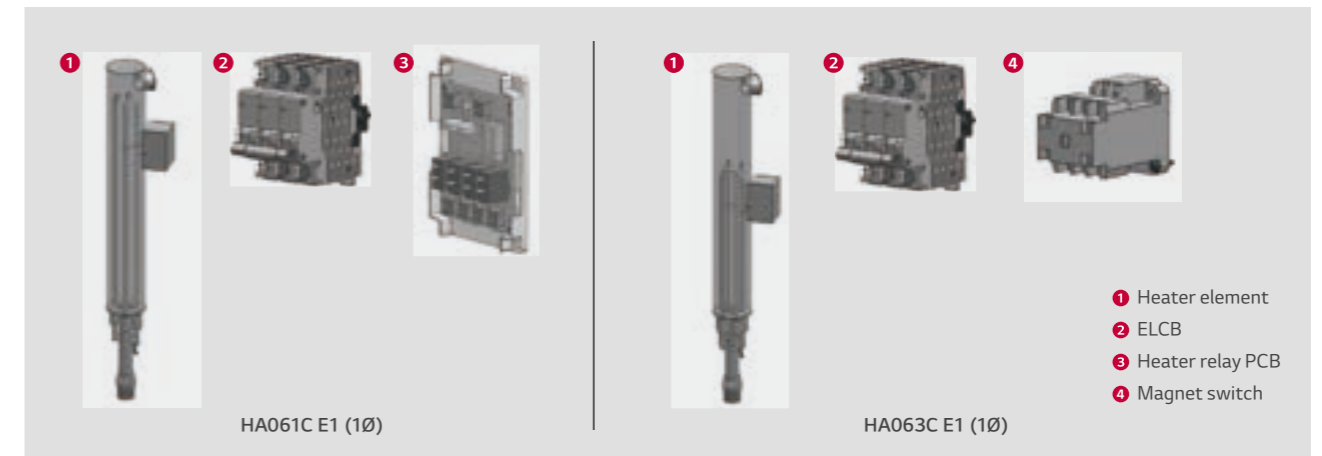

Electrical Specification			HA061C E1 (1Ø)	HA063C E1 (1Ø)
Backup Heater	Type	-	Sheath	
	No. of Heating Coil	EA	2	3
	Max. Power Consumption	kW	3.0 + 3.0	2.0 + 2.0 + 2.0
	Heating Step	Step	1	1
	Power Supply	V, Ø, Hz	220 - 240, 1, 50	380 - 415, 3, 50
	Current (rated)	A	24.0	8.7
	Circuit Breaker (ELCB)	A	40	20
Wiring Connection	Power Cable (included earth, H07RN-F)	mm ² x cores	6.0 x 3C	2.5 x 5C

Accessory Parts (Separately Provided)

Strainer

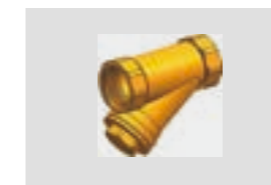

Technical Specification		Details
Material	Body	Brass
	Mesh	Stainless steel (STS304)
Mesh	Mesh No.	30
	Max. Particle Size	0.6mm
Piping Connection		Female G 1" according to ISO 228-1

PRODUCT SPECIFICATION

Performance Table for Heating Operation

Maximum Heating Capacity (Including Defrost Effect)

HU121MRB U30 / HU123MRB U30 + HN1600MC NK1

Outdoor Temperature	LWT 30 °C	LWT 35 °C	LWT 40 °C	LWT 45 °C	LWT 50 °C	LWT 55 °C	LWT 60 °C	LWT 65 °C
	TC	TC	TC	TC	TC	TC	TC	TC
-25°C DB	9.66	8.85	8.42	8.29	-	-	-	-
-20°C DB	10.13	10.00	9.88	9.75	9.63	-	-	-
-15°C DB	11.50	11.50	11.50	11.50	11.50	11.50	-	-
-7°C DB	12.00	12.00	12.00	12.00	12.00	12.00	12.00	-
-4°C DB	12.00	12.00	12.00	12.00	12.00	12.00	12.00	12.00
-2°C DB	12.00	12.00	12.00	12.00	12.00	12.00	12.00	12.00
2°C DB	12.00	12.00	12.00	12.00	12.00	12.00	12.00	12.00
7°C DB	12.00	12.00	12.00	12.00	12.00	12.00	12.00	12.00
10°C DB	12.00	12.00	12.00	12.00	12.00	12.00	12.00	12.00
15°C DB	12.00	12.00	12.00	12.00	12.00	12.00	12.00	12.00
18°C DB	12.00	12.00	12.00	12.00	12.00	12.00	12.00	12.00
20°C DB	12.00	12.00	12.00	12.00	12.00	12.00	12.00	12.00
35°C DB	12.00	12.00	12.00	12.00	12.00	12.00	12.00	12.00

HU141MRB U30 / HU143MRB U30 + HN1600MC NK1

Outdoor Temperature	LWT 30 °C	LWT 35 °C	LWT 40 °C	LWT 45 °C	LWT 50 °C	LWT 55 °C	LWT 60 °C	LWT 65 °C
	TC	TC	TC	TC	TC	TC	TC	TC
-25°C DB	10.04	9.21	8.76	8.62	-	-	-	-
-20°C DB	11.82	11.25	10.95	10.67	10.59	-	-	-
-15°C DB	12.52	12.90	13.26	12.88	12.81	12.63	-	-
-7°C DB	14.00	14.00	14.00	14.00	14.00	14.00	14.00	-
-4°C DB	14.00	14.00	14.00	14.00	14.00	14.00	14.00	14.00
-2°C DB	14.00	14.00	14.00	14.00	14.00	14.00	14.00	14.00
2°C DB	14.00	14.00	14.00	14.00	14.00	14.00	14.00	14.00
7°C DB	14.00	14.00	14.00	14.00	14.00	14.00	14.00	14.00
10°C DB	14.00	14.00	14.00	14.00	14.00	14.00	14.00	14.00
15°C DB	14.00	14.00	14.00	14.00	14.00	14.00	14.00	14.00
18°C DB	14.00	14.00	14.00	14.00	14.00	14.00	14.00	14.00
20°C DB	14.00	14.00	14.00	14.00	14.00	14.00	14.00	14.00
35°C DB	14.00	14.00	14.00	14.00	14.00	14.00	14.00	14.00

HU161MRB U30 / HU163MRB U30 + HN1600MC NK1

Outdoor Temperature	LWT 30 °C	LWT 35 °C	LWT 40 °C	LWT 45 °C	LWT 50 °C	LWT 55 °C	LWT 60 °C	LWT 65 °C
	TC	TC	TC	TC	TC	TC	TC	TC
-25°C DB	10.98	10.00	9.50	9.33	-	-	-	-
-20°C DB	13.43	12.54	12.03	11.78	11.47	-	-	-
-15°C DB	14.23	14.39	14.50	13.95	13.86	13.12	-	-
-7°C DB	16.00	16.00	16.00	16.00	16.00	16.00	16.00	-
-4°C DB	16.00	16.00	16.00	16.00	16.00	16.00	16.00	16.00
-2°C DB	16.00	16.00	16.00	16.00	16.00	16.00	16.00	16.00
2°C DB	16.00	16.00	16.00	16.00	16.00	16.00	16.00	16.00
7°C DB	16.00	16.00	16.00	16.00	16.00	16.00	16.00	16.00
10°C DB	16.00	16.00	16.00	16.00	16.00	16.00	16.00	16.00
15°C DB	16.00	16.00	16.00	16.00	16.00	16.00	16.00	16.00
18°C DB	16.00	16.00	16.00	16.00	16.00	16.00	16.00	16.00
20°C DB	16.00	16.00	16.00	16.00	16.00	16.00	16.00	16.00
35°C DB	16.00	16.00	16.00	16.00	16.00	16.00	16.00	16.00

Note

- DB : Dry Bulb Temperature (°C), LWT : Leaving Water Temperature (°C), LPM : Liters Per Minute (ℓ/min), TC : Total Capacity (kW)
- Direct interpolation is permissible. Do not extrapolate.
- Measuring procedure follows EN-14511.
 - Rated values are based on standard conditions and it can be found on specifications.
 - Above table values may not be matched according to installation condition. Except for rated value, the performance is not guaranteed.
 - In accordance with the test standard (or nations), the rating will vary slightly.
- The shaded areas are not guaranteed continuous operation.

Performance Table for Cooling Operation

Maximum Cooling Capacity

HU121MRB U30 / HU123MRB U30 + HN1600MC NK1

Outdoor Temperature	LWT 7°C	LWT 10°C	LWT 13°C	LWT 15°C	LWT 18°C	LWT 20°C	LWT 22°C
	TC	TC	TC	TC	TC	TC	TC
10°C DB	12.00	12.00	12.00	12.00	12.00	12.00	12.00
20°C DB	12.00	12.00	12.00	12.00	12.00	12.00	12.00
30°C DB	12.00	12.00	12.00	12.00	12.00	12.00	12.00
35°C DB	12.00	12.00	12.00	12.00	12.00	12.00	12.00
40°C DB	11.75	12.00	12.00	12.00	12.00	12.00	12.00
45°C DB	11.50	12.00	12.00	12.00	12.00	12.00	12.00

HU141MRB U30 / HU143MRB U30 + HN1600MC NK1

Outdoor Temperature	LWT 7°C	LWT 10°C	LWT 13°C	LWT 15°C	LWT 18°C	LWT 20°C	LWT 22°C
	TC	TC	TC	TC	TC	TC	TC
10°C DB	14.00	14.00	14.00	14.00	14.00	14.00	14.00
20°C DB	14.00	14.00	14.00	14.00	14.00	14.00	14.00
30°C DB	14.00	14.00	14.00	14.00	14.00	14.00	14.00
35°C DB	14.00	14.00	14.00	14.00	14.00	14.00	14.00
40°C DB	13.75	14.00	14.00	14.00	14.00	14.00	14.00
45°C DB	13.50	14.00	14.00	14.00	14.00	14.00	14.00

HU161MRB U30 / HU163MRB U30 + HN1600MC NK1

Outdoor Temperature	LWT 7°C	LWT 10°C	LWT 13°C	LWT 15°C	LWT 18°C	LWT 20°C	LWT 22°C
	TC	TC	TC	TC	TC	TC	TC
10°C DB	16.00	16.00	16.00	16.00	16.00	16.00	16.00
20°C DB	16.00	16.00	16.00	16.00	16.00	16.00	16.00
30°C DB	16.00	16.00	16.00	16.00	16.00	16.00	16.00
35°C DB	16.00	16.00	16.00	16.00	16.00	16.00	16.00
40°C DB	15.75	16.00	16.00	16.00	16.00	16.00	16.00
45°C DB	15.50	16.00	16.00	16.00	16.00	16.00	16.00

Note

- DB : Dry Bulb Temperature (°C), LWT : Leaving Water Temperature (°C), LPM : Liters Per Minute (ℓ/min), TC : Total Capacity (kW)
- Direct interpolation is permissible. Do not extrapolate.
- Measuring procedure follows EN-14511.
 - Rated values are based on standard conditions and it can be found on specifications.
 - Above table values may not be matched according to installation condition. Except for rated value, the performance is not guaranteed.
 - In accordance with the test standard (or nations), the rating will vary slightly.
- The shaded areas are not guaranteed continuous operation.

THERMA V™ R32 HYDROSPLIT HYDRO BOX
PRODUCT SPECIFICATION

Drawings

Category	Unit	Model Name		
		Capacity (kW)		
		12.0	14.0	16.0
1 Phase Model 220 - 240V, 1Ø, 50Hz	Outdoor Unit	HU121MRB U30	HU141MRB U30	HU161MRB U30
	Indoor Unit	HN1600MC NK1		
3 Phase Model 380 - 415V, 3Ø, 50Hz	Outdoor Unit	HU123MRB U30	HU143MRB U30	HU163MRB U30
	Indoor Unit	HN1600MC NK1		

HU121MRB U30 / HU141MRB U30 / HU161MRB U30
 HU123MRB U30 / HU143MRB U30 / HU163MRB U30 [Unit : mm]

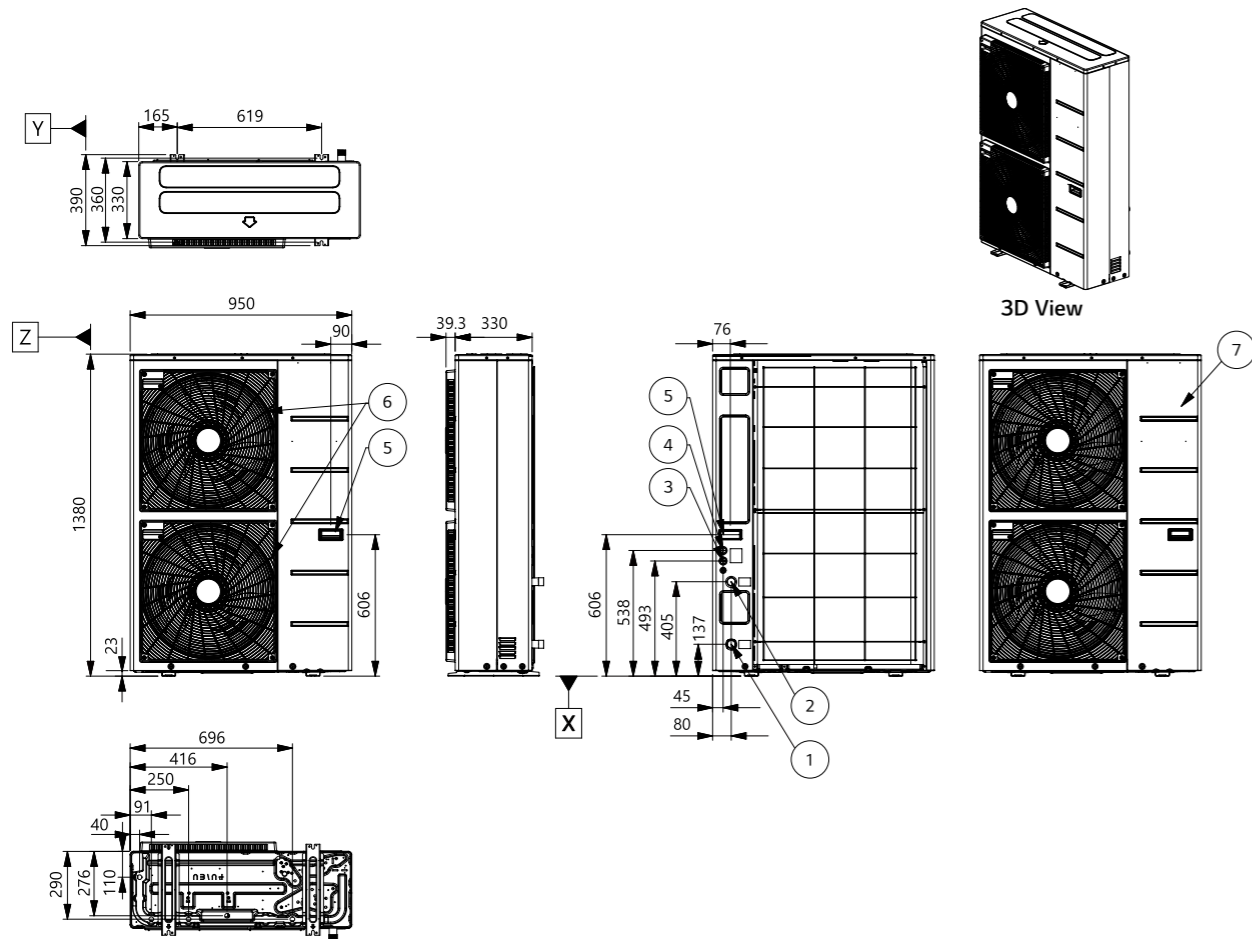

No.	Part Name	Description
1	Entering Water Pipe	Male PT 1" according to ISO 7-1 (tapered pipe threads)
2	Leaving Water Pipe	Male PT 1" according to ISO 7-1 (tapered pipe threads)
3	Unit Power	Power cable hole
4	Low Voltage	Communication cable hole
5	Handle	-
6	Air Outlet	-
7	Side Panel	-

HN1600MC NK1 [Unit : mm]
 External

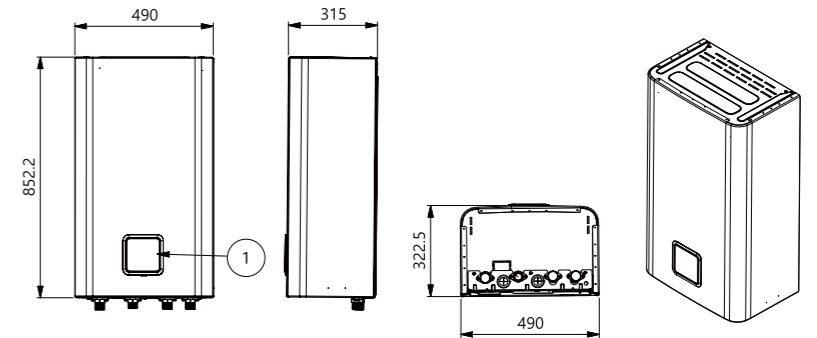

No.	Part Name	Description
1	Control Panel	Built-in remote controller

Internal

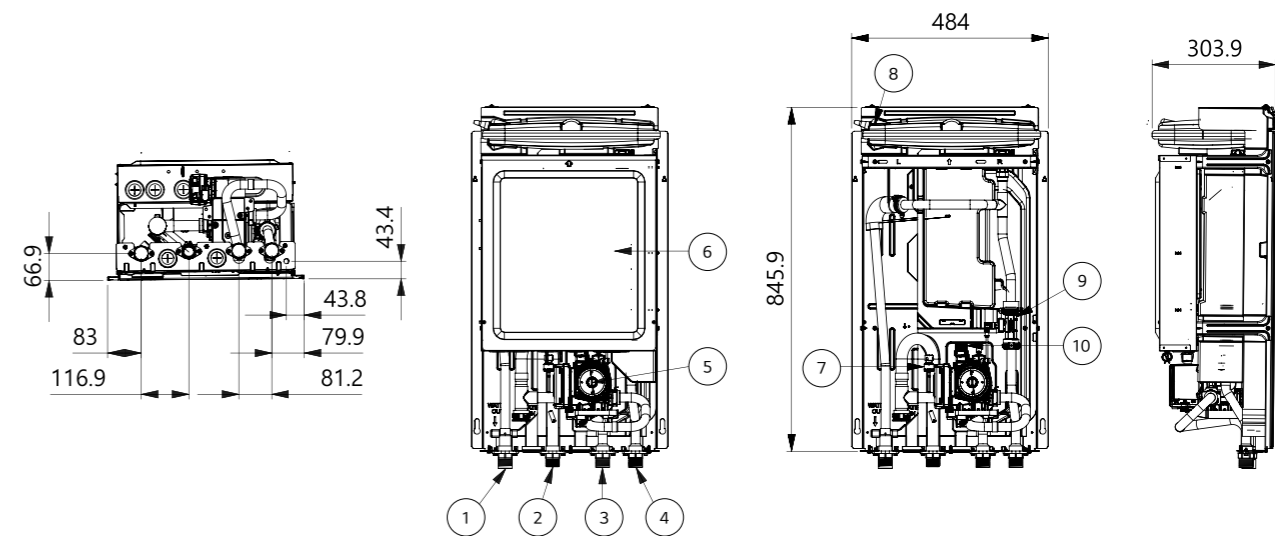









No.	Part Name	Description
1	Heating Circuit Outlet Pipe	Male PT 1" according to ISO 7-1 (tapered pipe threads)
2	Heating Circuit Inlet Pipe	Male PT 1" according to ISO 7-1 (tapered pipe threads)
3	Outlet Pipe to Outdoor Unit	Male PT 1" according to ISO 7-1 (tapered pipe threads)
4	Inlet Pipe to Outdoor Unit	Male PT 1" according to ISO 7-1 (tapered pipe threads)
5	Water Pump	GRUNDFOS UPML 20-105 CHBL
6	Control Box	PCB and Terminal blocks
7	Pressure Sensor	SENSATA 2HMP3-04W, 0-2Mpa
8	Expansion Tank	8 Liter, 3/4" connection
9	Flow Sensor	Flow range : 5 - 80 LPM
10	Safety Valve	Open at water pressure 3 bar



THERMAV™
ACCESSORIES





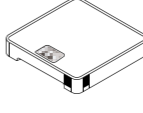

Accessories Provided by LG

Category	Model Name	Model Number	Figure	Applicable Product	Relevant Function	Purpose	Feature
Sensors	Room Temperature Sensor	PQRSTA0		All Therma V products	Room Temperature Based Control	To detect room air temperature for room temperature based control	• Max. wire length : 15m
	Thermistor for 2 nd Circuit or E/Heater	PRSTAT5K10		All except for High Temperature	2 nd Circuit (mixing circuit)	To detect 2 nd circuit temperature when using 2 nd circuit function	• 5kΩ thermistor, 10m
	Domestic Hot Water Sensor	PHRSTA0		All except for R32 Split IWT and R32 Hydrosplit IWT	Domestic Hot Water Heating	To detect DHW tank temperature	• Included in PHLTA kit
Valves	3 Way Valve	OSHA-3V		All except for R32 Split IWT and R32 Hydrosplit IWT	Domestic Hot Water Heating	To divert water flow between space heating and DHW heating	• Size : DN 20 G 1" connection, male threaded
	Thermostatic Mixing Valve	OSHA-MV OSHA-MV1		Regardless of model	Domestic Hot Water Supply	To blend hot water with cold water for ensuring constant, safe shower and bath outlet temp.	• Size : 3/4" DN20 male threaded • Size : 1" DN25 male threaded
DHW Tanks	Domestic Hot Water Tank (single coil)	OSHW-200F OSHW-300F OSHW-500F		All except for R32 Split IWT and R32 Hydrosplit IWT	Domestic Hot Water Heating	To generate and store domestic hot water	• Storage volume : 200L, 300L, 500L • Type : Internal double coil • Material : Stainless steel • Capacity of booster heater : 2.4kW
	Domestic Hot Water Tank (double coil)	OSHW-300FD		All except for R32 Split IWT, R32 Hydrosplit IWT and High Temperature			• Storage volume : 300L • Type : Internal double coil • Material : Stainless steel • Capacity of booster heater : 2.4kW
Installation Kits	Domestic Hot Water Tank Kit	PHLTA		R32 Split Hydro Box, R410A Split Hydro Box, R32 Hydrosplit Hydro Box	Domestic Hot Water Heating	To operate with DHW tank	• Parts included : DHW tank sensor (thermistor), Circuit breaker, Relay
		PHLTC		R410A Split Hydro Box (HN1639 NK3, 3Ø only)			• Parts included : DHW tank sensor (thermistor), Circuit breaker, Relay, Multi harness
		PHLTB	R32 Monobloc, R32 Monobloc S				
	Solar Thermal Kit	PHLLA		R32 Monobloc, R410A Split Hydro Box (HN1639 NK3, 3Ø only)	Solar Thermal Heat Utilization	To operate with solar thermal system	• Length of thermistor : 12m • Size of tube connector (W x H x D) : 110 x 55 x 22

Category	Model Name	Model Number	Figure	Applicable Product	Relevant Function	Purpose	Feature
Installation Kits	Electric Back Up Heater	HA031M E1		R32 Monobloc, R32 Monobloc S	Capacity Back Up & Emergency Operation	To supplement insufficient capacity	• Heater capacity : 3kW • Number of heating coil : 1EA (3.0kW) • Size (W x H x D) : 210 x 607 x 217 • Power : 220 - 240V, 1Ø
		HA061M E1					• Heater capacity : 6kW • Number of heating coil : 2EA (3.0 + 3.0kW) • Size (W x H x D) : 210 x 607 x 217 • Power : 220 - 240V, 1Ø
		HA063M E1					• Heater capacity : 6kW • Number of heating coil : 3EA (2.0 + 2.0 + 2.0kW) • Size (W x H x D) : 210 x 607 x 217 • Power : 380 - 415V, 3Ø
	HA061C E1	HA063C E1		R32 Hydrosplit Hydro Box (HN1600MC NK1)	Capacity Back Up & Emergency Operation	To supplement insufficient capacity	• Heater capacity : 6 kW • Number of heating coil : 2EA (3.0 + 3.0kW) • Power : 220-240 V, 1Ø • Heater capacity : 6 kW • Number of heating coil : 3EA (2.0 + 2.0 + 2.0kW) • Power : 220-240 V, 3Ø
Vessel	Buffer Tank for Space Heating	OSHB-40KT		R32 Split IWT and R32 Hydrosplit IWT	-	To provide the buffer volume of water to the heating circuit	• Volume : 40L • Size (W x H x D) : 518 x 560 x 175
	Expansion Vessel for DHW	OSHE-12KT		R32 Split IWT and R32 Hydrosplit IWT	-	To absorb the volume changes by temperature of water for the DHW circuit	• Volume : 8L • Connection : 3/4" • Max. pressure : 10 bar • Size (W x H x D) : 416 x 238 x 502
ETC	Extension Wire for Wire Remote Controller	PZCWRC1		All Therma V products	-	To extend wire between wired remote controller and indoor unit	• Length : 10m
	Extension Cable for Wi-Fi Modem	PWYREW000		All Therma V products	Wi-Fi Control via LG ThinQ	To extend wire between Wi-Fi modem and indoor unit	• Length : 10m
	2 Remote Control Wire	PZCWRC2		All Therma V products	2 Remote Control	To connect two remote controller on the one indoor unit	• Length : 0.25m
	Drain Pan	PHDPB PHDPC		R32 Split Hydro Box (HN0916M NK4), R410A Split Hydro Box (HN1616 NK3 / HN1639 NK3) R32 Hydrosplit, R32 Split Hydro Box (HN091MR NK5), R410A Split Hydro Box (HN1616M NK5 / HN1636M NK5)	Cooling Operation	To collect condensed water in indoor unit when cooling operation	-
Cover Plate	PDC-HK10		R32 Hydrosplit Hydro Box, R32 Hydrosplit IWT, R32 Split Hydro Box, R32 Split IWT, R410A Split Hydro Box	-	To fill the blank space of the indoor unit front panel when the remote controller is relocated indoors.	-	

Accessories Provided by LG

Category	Model Name	Model Number	Figure	Applicable Product	Relevant Function	Purpose	Feature
Remote Controller	Wired Remote Controller	PREMTW101		All Therma V products	2 Remote Control	To control AWHP using two remote controller (additional remote controller)	<ul style="list-style-type: none"> New modern design 4.3 inch color LCD display Information displayed with simple graphic, icon & text Built-in temperature sensor Size (W x H x D) : 120 x 120 x 16 Extension cable (PZCWRC1, 10m) and 2 remote cable (PZCWRC2, 0.25m) are included
Central Controller	AC Ez Touch	PACEZA000		All Therma V products	Centralized Control	To control AWHP using LG central controller	<ul style="list-style-type: none"> 5 inch color display User-friendly control with iconographic interface (touch screen) Max. 32 unit control Total 200 schedule events (weekly / monthly / yearly / exception day) Operation history Remote controller lock (all, temp, mode) PC access supported (IPv6 supported) DI 1EA (emergency stop only) Size (W x H x D) : 137 x 121 x 25
	AC Smart 5	PACS4B000 (Smart 4) PACS5A000 (Smart 5)					<ul style="list-style-type: none"> 10.2 inch color display User-friendly control with iconographic interface (touch screen) (Smart 4)_Max. IDU 32, (Smart 5)_Max. IDU 64 Total 100 schedule events (weekly / monthly / yearly / exception day) History / operation trend Interlock with 3rd party equipment (ACS IO, ACU IO module is needed) Error alarm by e-mail Remote controller lock (all, temp, mode) Map view (visual navigation) Web access supported with HTML5 (PC, smartphone, tablet) DI 2EA, DO 2EA BACnet IP/modbus TCP protocol support Size (W x H x D) : 253.2 x 167.7 x 28.9
	ACP 5	PACP4B000 (ACP4) PACP5A000 (ACP5)					<ul style="list-style-type: none"> Web access controller Max. 128 unit control Total 100 schedule events (weekly / monthly / yearly / exception day) History / operation trend Interlock with 3rd party equipment (ACS IO, ACU IO module is needed) Error alarm by e-mail Remote controller lock (all, temp, mode) Map view (visual navigation) DI 10EA, DO 4EA BACnet IP/modbus TCP protocol support Size (W x H x D) : 270 x 155 x 65

Category	Model Name	Model Number	Figure	Applicable Product	Relevant Function	Purpose	Feature
Gateway	ACP Lonworks	PLNWKB000		All Therma V products	Centralized Control	To link with AWHP and other existing building control system	<ul style="list-style-type: none"> Web access controller Max. 64 unit control ACP function included Lonworks protocol support Size (W x H x D) : 270 x 155 x 65
	Modbus RTU Gateway	PMBUSB00A				To communicate and control through the central controller (providing modbus RTU connection between AWHP and BMS)	<ul style="list-style-type: none"> Modbus RTU slave (RS485) / 9,600 bps Size (W x H x D) : 53.6 x 89.7 x 60.7 Max. 16 IDUs with single module / Max. 64 IDUs with 4 modules Power : DC 12V
	PI485 Gateway	PMNFP14A1				To communicate and control through the central controller (converting LG protocol to RS485 protocol)	<ul style="list-style-type: none"> 1 for each outdoor unit Power : Supplied by outdoor unit
Dry Contact	Simple Dry Contact	PDRYCB000		All Therma V products	-	To connect between the AWHP and external devices to control various functions	<ul style="list-style-type: none"> 1 Set per 1 unit 1 Input contact for turning on/off Input power : 220 - 240V 2 output contacts - Operation status - Error status
	Dry Contact for Thermostat	PDRYCB320					<ul style="list-style-type: none"> 1 Set per 1 unit Non voltage or 12 - 24V 8 digital input contacts for thermostat - On/off operation mode, DHW heating - Emergency mode, silent mode 2 Output contacts - Operation status - Error status
ETC	LG Wi-Fi Modem	PWFMDD200		All Therma V products	Wi-Fi Control via LG ThinQ	To control AWHP via smartphone	<ul style="list-style-type: none"> Basic control function - On/off, operation mode, set temp - DHW heating and set temp Weekly on/off schedule Error status check Frequency : 2.4GHz IEEE 802.11b/g/n supported
	Meter Interface	PENKTH000				Energy Monitoring	To measure production / consumption power

Note
1. PI485 Gateway (PMNFP14A1) should be installed on outdoor unit to use central controller.

LG Wi-Fi Modem

PWFMDD200 ENCXLEU

Access LG THERMA V anytime and from anywhere with Wi-Fi equipped device. LG's exclusive Home Appliances control app (LG ThinQ) is available.

Simple operation for various functions.

- On/off
- Operation mode selection
- Current temperature
- Set temperature
- On/off reservation scheduling
- Energy monitoring
- ESS monitoring
- Silent mode reservation
- Holiday mode
- Quick DHW heating



Model Name	PWFMDD200
Size (mm)	46 x 68 x 14
Interfaceable Products	All THERMA V Line-ups except for R410A IWT
Connection Type	Indoor Unit 1 : 1
Communication Frequency	2.4GHz
Wireless Standards	IEEE 802.11b/g/n
Mobile Application	LG ThinQ (Android v4.1 (Jellybean) or higher, iPhone iOS 9.0 or higher)
Optional Extension Cable	PWYREW000 (10m extension)

Note

1. Functionality may be different according to each Indoor model.
2. User interface of application shall be revised for its design and contents improvement.
3. Application is optimized for smartphone use, so it may not be well functioning with tablet devices.
 - For the compatibility with indoor unit, please contact regional office.